



**SIDE-HINGED WOOD-EDGE STEEL DOOR UNIT
6'-8" DOUBLE DOOR WITH / WITHOUT SIDELITES**

GENERAL NOTES

- EVALUATED FOR USE IN LOCATIONS ADHERING TO THE FLORIDA BUILDING CODE AND WHERE PRESSURE REQUIREMENTS AS DETERMINED BY ASCE 7, MINIMUM DESIGN LOADS FOR BUILDINGS AND OTHER STRUCTURES, DOES NOT EXCEED THE DESIGN PRESSURES LISTED.
- HURRICANE PROTECTIVE SYSTEM (SHUTTERS) IS NOT REQUIRED ON OPAQUE PANELS, BUT IS REQUIRED ON GLAZED SIDELITES.
- POLYURETHANE CORE FLAME SPREAD INDEX OF 50 AND SMOKE DEVELOPED INDEX OF 60 PER ASTM E84.
- PLASTICS TESTING OF LITE FRAME MATERIAL:

TEST DESCRIPTION	DESIGNATION	RESULT
SELF IGNITION TEMP	ASTM D1929	680 °F > 650 °F
RATE OF BURNING	ASTM D635	1.10 IN/MIN
SMOKE DENSITY	ASTM D2843	69.6%
TENSILE STRENGTH*	ASTM D638	-7.48% DIFF

* COMPARATIVE TENSILE STRENGTH AFTER WEATHERING
4500 HOURS XENON ARC METHOD 1

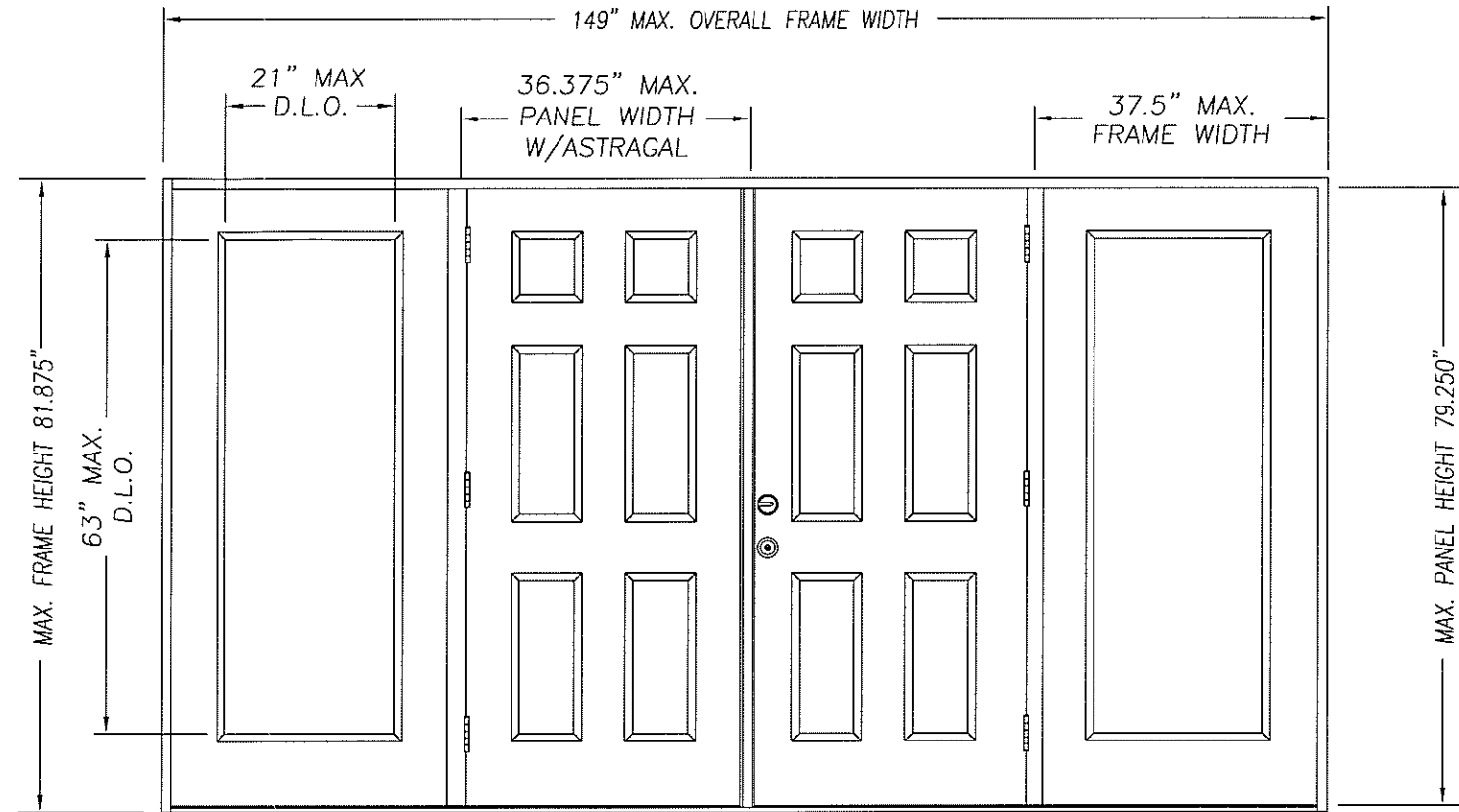

DOUBLE DOOR UNIT W/SIDELITES

Addendum to NAMI

Certification No.: N1006110-R3
 Reviewed By: [Signature]
 Date Reviewed: 12/18/08

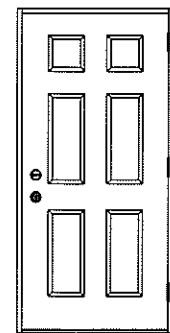

SINGLE DOOR UNIT

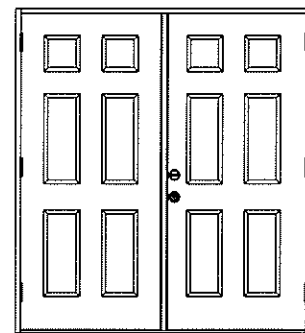

DOUBLE DOOR UNIT

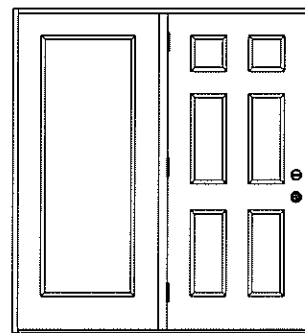

SINGLE DOOR UNIT
WITH SIDELITE

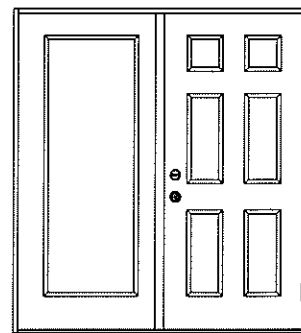

SINGLE DOOR UNIT
WITH SIDELITE

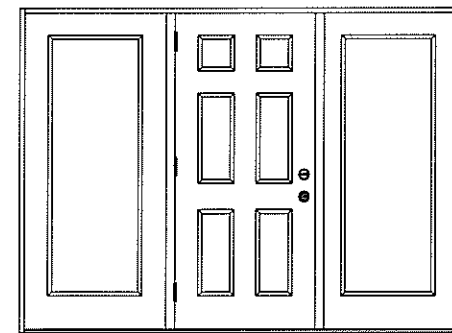

SINGLE DOOR UNIT W/SIDELITES

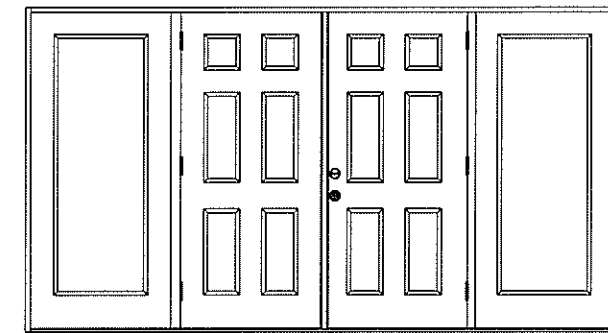

DOUBLE DOOR UNIT W/SIDELITES

TABLE OF CONTENTS	
SHEET #	DESCRIPTION
1	TYPICAL ELEVATIONS & GENERAL NOTES
2	ANCHORING LOCATIONS & DETAILS
3	ANCHORING LOCATIONS & DETAILS

CONFIG	MAX WIDTH	DESIGN PRESSURE RATING		WHERE WATER INFILTRATION PERFORMANCE IS REQUIRED TO BE 15% OF DESIGN PRESSURE			
		INSWING	OUTSWING	INSWING		OUTSWING	
X	37.5"	+76.0 / -76.0	+76.0 / -76.0	+19.0 / -19.0	+55.0 / -55.0	+19.0 / -19.0	+55.0 / -55.0
XX	74"	+55.0 / -55.0	+55.0 / -55.0	+19.0 / -19.0	+55.0 / -55.0	+19.0 / -19.0	+55.0 / -55.0
OX or XO	75"	+55.0 / -55.0	+55.0 / -55.0	+19.0 / -19.0	+55.0 / -55.0	+19.0 / -19.0	+55.0 / -55.0
OXO	112.5"	+55.0 / -55.0	+55.0 / -55.0	+19.0 / -19.0	+55.0 / -55.0	+19.0 / -19.0	+55.0 / -55.0
OXXO	149"	+55.0 / -55.0	+55.0 / -55.0	+19.0 / -19.0	+55.0 / -55.0	+19.0 / -19.0	+55.0 / -55.0

MASONITE INTERNATIONAL CORP.
 7300 REAMES RD.
 CHARLOTTE, NC 28216

PRODUCT:	"EXTERIOR DOOR PRODUCT" DOUBLE 6'8" OPAQUE WOOD-EDGE STEEL DOOR
PART OR ASSEMBLY:	TYPICAL ELEVATIONS & GENERAL NOTES
NO.	REVISIONS
C	12/15/08 ADDED SPACER
B	1/2/08 HINGE SCREW LENGTH
	DATE
	BY
	SWS
	SWS

DATE: 7/11/05
 SCALE: N.T.S.
 DWG. BY: SWS
 CHK. BY:
 DRAWING NO.:
 DWG-MA-FL0128-05
 SHEET 1 OF 3

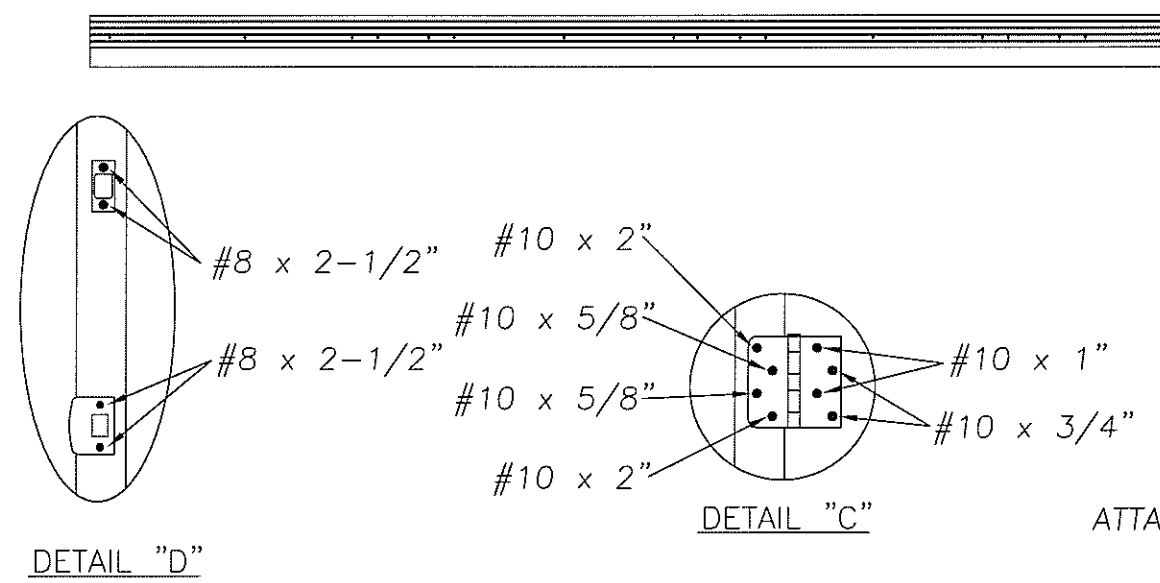
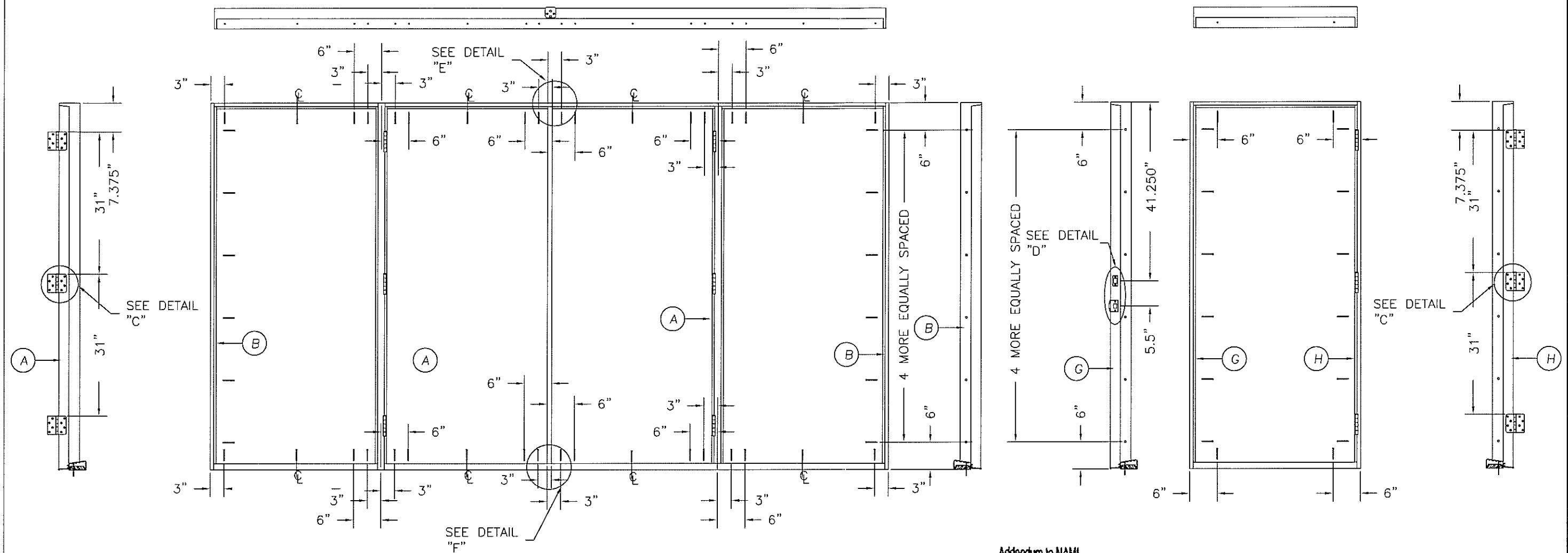

DETAIL "E" ASTRAGAL
 ATTACH ASTRAGAL RETAINER BOLT STRIKE PLATE TO FRAME AS SHOWN.

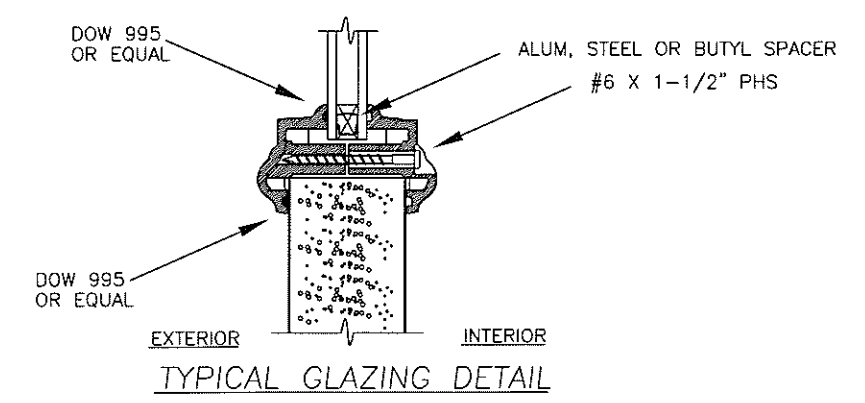
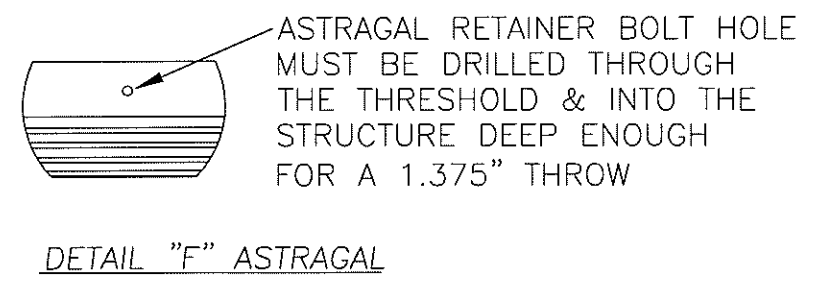

Addendum to NAMI
 Certification No.: N1006110-R3
 Reviewed By: [Signature]
 Date Reviewed: 12/18/08

MASONITE INTERNATIONAL CORP.
 7300 REAMES RD.
 CHARLOTTE, NC 28216

PRODUCT: "EXTERIOR DOOR PRODUCT"
 DOUBLE 6"-8" OPAQUE
 WOOD-EDGE STEEL DOOR
 PART OR ASSEMBLY:
 ANCHORING LOCATIONS
 & DETAILS

NO.	DATE	REVISIONS
C	12/15/08	ADDED SPACER
B	1/2/08	HINGE SCREW LENGTH
		SWS
		BY

DATE: 7/11/05
 SCALE: N.T.S.
 DWG. BY: SWS
 CHK. BY:
 DRAWING NO.:
 DWG-MA-FL0128-05
 SHEET 2 OF 3

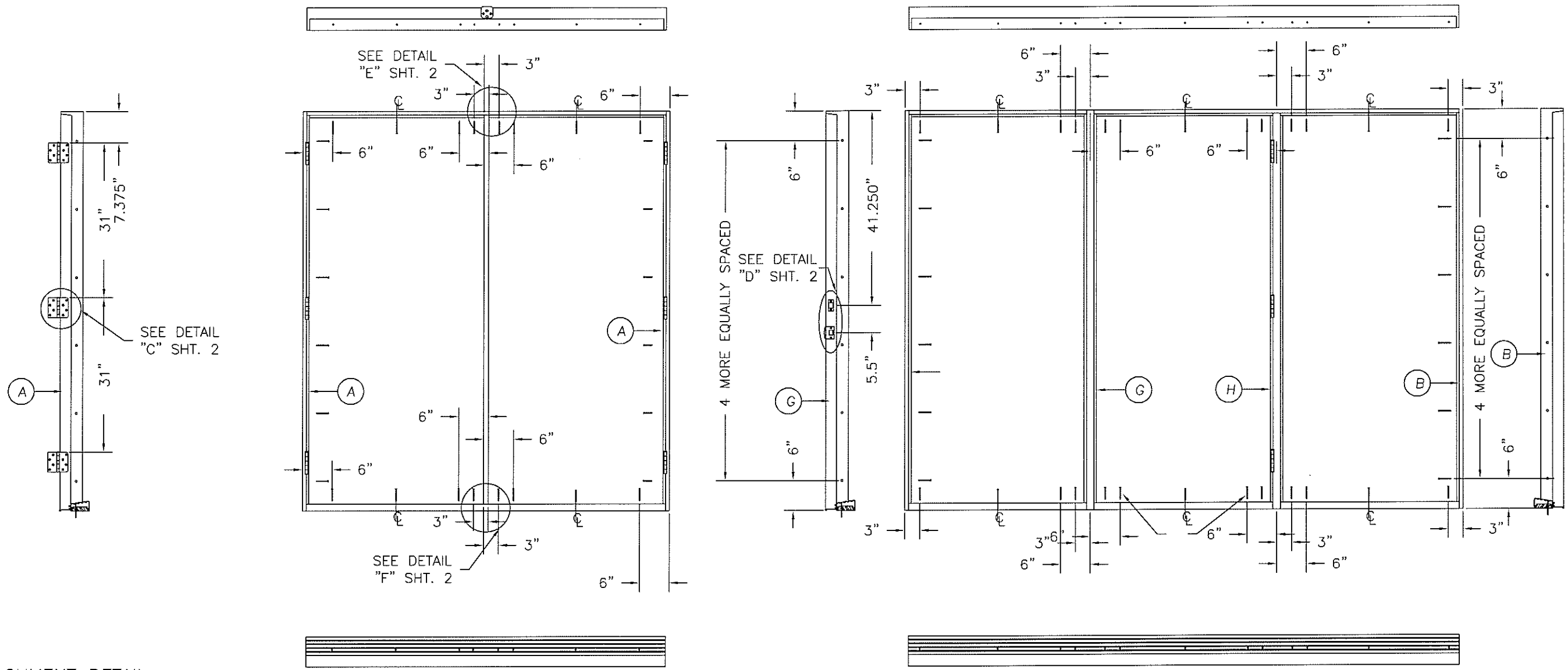

ATTACHMENT DETAIL

1. ANCHOR ANALYSIS FOR LOADING CONDITIONS PREPARED, SIGNED AND SEALED BY HAROLD E. RUPP, PE (FLORIDA #15935) WITH THE LOWEST (LEAST) FASTENER RATING FROM THE DIFFERENT FASTENERS BEING CONSIDERED FOR USE. JAMB, HEAD, AND THRESHOLD FASTENERS ANALYZED FOR THIS UNIT INCLUDE #10 WOOD SCREWS OR 3/16" TAPCONS. A PHYSICAL SHIM MUST BE PLACED IN SHIM SPACE AT EACH ANCHOR LOCATION.
2. THE WOOD SCREW SINGLE SHEAR DESIGN VALUES COME FROM ANSI/AF&PA NDA FOR SOUTHERN PINE LUMBER AND ACHIEVEMENT OF 1-1/2" MINIMUM EMBEDMENT. THE TAPCON MUST ACHIEVE MINIMUM EMBEDMENT OF 1-1/4".
3. WOOD BUCKS BY OTHERS MUST BE ANCHORED PROPERLY TO TRANSFER LOADS TO STRUCTURE.
4. MINIMUM DESIGN VALUE STRENGTH OF ANCHORS 171 LBS.

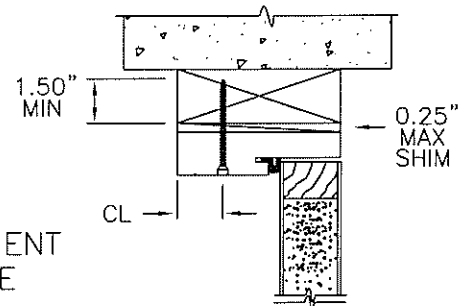

TYPICAL ANCHOR INSTALLATION

HARDWARE SCHEDULE

- | | |
|----|---|
| 1. | KWIKSET MAXIMUM SECURITY SERIES GRADE 2 CYLINDRICAL AND DEADLOCK HARDWARE TO BE INSTALLED AT 5-1/2" CENTERLINE. |
| 2. | 4" X 4" FULL MORTISE BUTT HINGES |

Addendum to NAMI
 Certification No.: N1006110-R3
 Reviewed By: [Signature]
 Date Reviewed: 12/18/08

PRODUCT:		"EXTERIOR DOOR PRODUCT"	
		6'-8" WOOD-EDGE STEEL OPAQUE DOUBLE DOOR UNIT	
PART OR ASSEMBLY:		ANCHORING LOCATIONS & DETAILS	
		SWS	BY
	ADDED SPACER	12/15/08	C
	HINGE SCREW LENGTH	1/2/08	B
		DATE	NO.
			REVISIONS
DATE:		7/11/05	
SCALE:		N.T.S.	
DWG. BY:		SWS	
CHK. BY:			
DRAWING NO.:		DWG-MA-FL0128-05	
SHEET		3 OF 3	