



**SIDE-HINGED METAL-EDGE STEEL DOOR UNIT
8'-0" GLAZED DOUBLE DOOR**

GENERAL NOTES

1. EVALUATED FOR USE IN LOCATIONS ADHERING TO THE FLORIDA BUILDING CODE AND WHERE PRESSURE REQUIREMENTS AS DETERMINED BY ASCE 7, MINIMUM DESIGN LOADS FOR BUILDINGS AND OTHER STRUCTURES, DOES NOT EXCEED THE DESIGN PRESSURES LISTED.
2. HURRICANE PROTECTIVE SYSTEM (SHUTTERS) IS REQUIRED.
3. POLYURETHANE CORE FLAME SPREAD INDEX OF 50 AND SMOKE DEVELOPED INDEX OF 60 PER ASTM E84.
4. PLASTICS TESTING OF LITE FRAME MATERIAL:

TEST DESCRIPTION	DESIGNATION	RESULT
SELF IGNITION TEMP	ASTM D1929	680 °F > 650 °F
RATE OF BURNING	ASTM D635	1.10 IN/MIN
SMOKE DENSITY	ASTM D2843	69.6%
TENSILE STRENGTH*	ASTM D638	-7.48% DIFF

* COMPARATIVE TENSILE STRENGTH AFTER WEATHERING
4500 HOURS XENON ARC METHOD 1

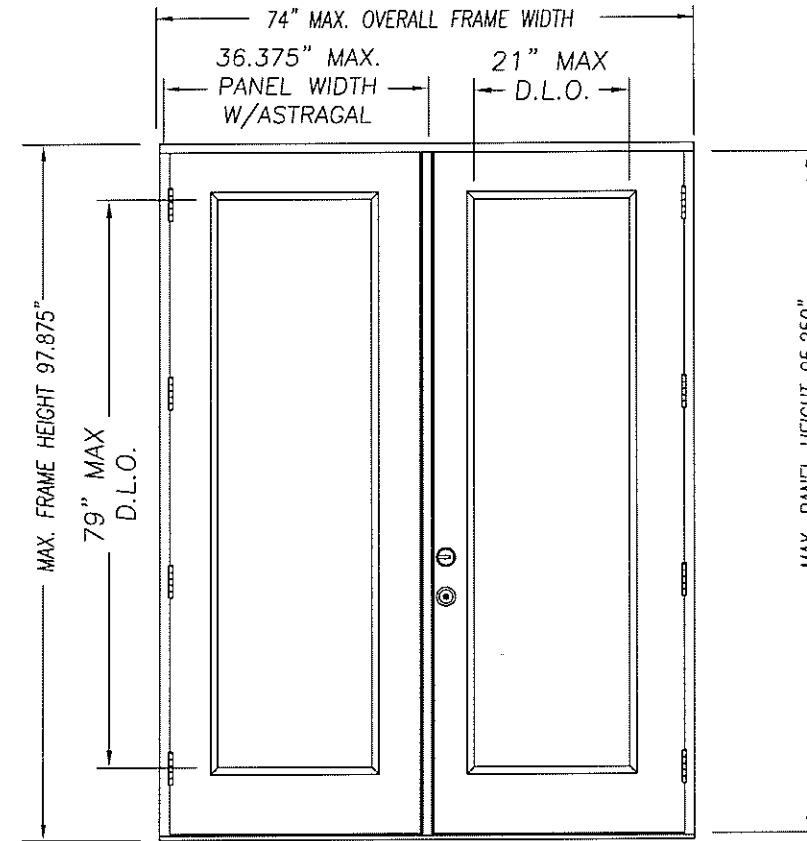

DOUBLE DOOR UNIT

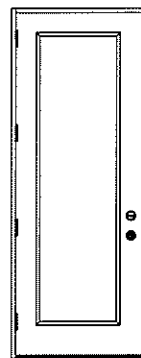

SINGLE DOOR UNIT

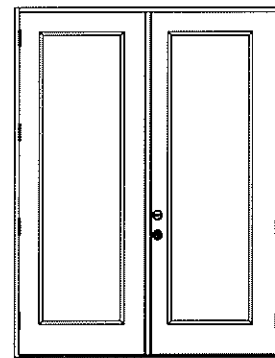

DOUBLE DOOR UNIT

Addendum to NAMI
 Certification No.: NI006115-R2
 Reviewed By: [Signature]
 Date Reviewed: 12/18/08

TABLE OF CONTENTS	
SHEET #	DESCRIPTION
1	TYPICAL ELEVATIONS & GENERAL NOTES
2	ANCHORING LOCATIONS & DETAILS
3	ANCHORING LOCATIONS & DETAILS

CONFIG	MAX WIDTH	DESIGN PRESSURE RATING		WHERE WATER INFILTRATION PERFORMANCE IS REQUIRED TO BE 15% OF DESIGN PRESSURE	
		INSWING	OUTSWING	INSWING	OUTSWING
X	37.5"	+43.0 / -45.0	+43.0 / -45.0	+19.0 / -19.0	+43.0 / -45.0
XX	74"	+43.0 / -45.0	+43.0 / -45.0	+19.0 / -19.0	+43.0 / -45.0

MASONITE INTERNATIONAL CORP.
 7300 REAMES RD.
 CHARLOTTE, NC 28216

PRODUCT:	"EXTERIOR DOOR PRODUCT" DOUBLE 8'0" GLAZED METAL-EDGE STEEL DOOR
PART OR ASSEMBLY:	TYPICAL ELEVATIONS & GENERAL NOTES
NO.	A
DATE	12/15/08
ADDED SPACER	SWS
BY	BY
REVISIONS	

DATE: 7/25/05
 SCALE: N.T.S.
 DWG. BY: SWS
 CHK. BY:
 DRAWING NO.:
 DWG-MA-FL0135-05
 SHEET 1 OF 3

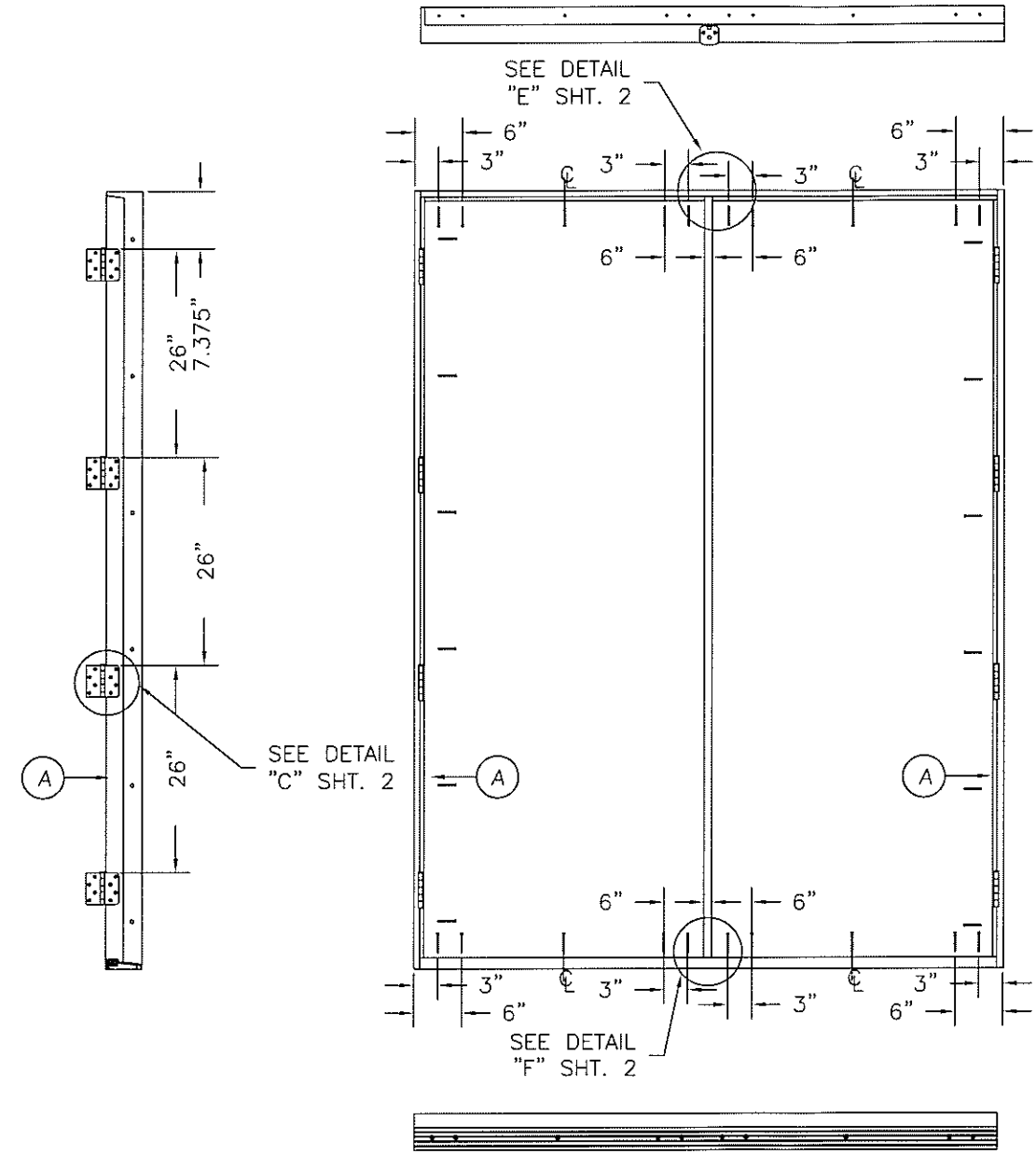

Addendum to NAM
 Certification No.: 11006115-R2
 Reviewed By: [Signature]
 Date Reviewed: 12/18/08

ATTACHMENT DETAIL

1. ANCHOR ANALYSIS FOR LOADING CONDITIONS PREPARED, SIGNED AND SEALED BY HAROLD E. RUPP, PE (FLORIDA #15935) WITH THE LOWEST (LEAST) FASTENER RATING FROM THE DIFFERENT FASTENERS BEING CONSIDERED FOR USE. JAMB, HEAD, AND THRESHOLD FASTENERS ANALYZED FOR THIS UNIT INCLUDE #10 WOOD SCREWS OR 3/16" TAPCONS. A PHYSICAL SHIM MUST BE PLACED IN SHIM SPACE AT EACH ANCHOR LOCATION.
2. THE WOOD SCREW SINGLE SHEAR DESIGN VALUES COME FROM ANSI/AF&PA NDA FOR SOUTHERN PINE LUMBER AND ACHIEVEMENT OF 1-1/2" MINIMUM EMBEDMENT. THE TAPCON MUST ACHIEVE MINIMUM EMBEDMENT OF 1-1/4".
3. WOOD BUCKS BY OTHERS MUST BE ANCHORED PROPERLY TO TRANSFER LOADS TO STRUCTURE.
4. MINIMUM DESIGN VALUE STRENGTH OF ANCHORS 171 LBS.

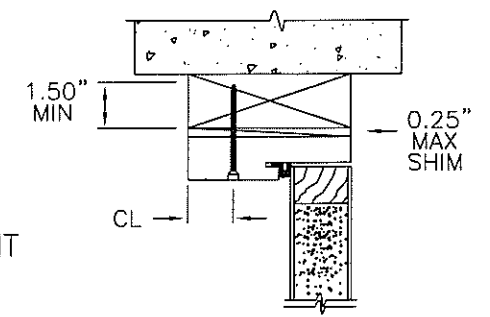

TYPICAL ANCHOR INSTALLATION

HARDWARE SCHEDULE

1.	KWIKSET MAXIMUM SECURITY SERIES GRADE 2 CYLINDRICAL AND DEADLOCK HARDWARE TO BE INSTALLED AT 10-1/2" CENTERLINE.
1a.	KWIKSET MAXIMUM SECURITY SERIES GRADE 2 CYLINDRICAL AND DEADLOCK HARDWARE TO BE INSTALLED AT 5-1/2" CENTERLINE WITH 8" GRADE 1 (ANSI/BHMA A156.16) SURFACE BOLTS INSTALLED ON LATCH SIDE OF ACTIVE DOOR PANEL - (1) AT TOP AND (1) AT BOTTOM.
2.	4" X 4" FULL MORTISE BUTT HINGES

PRODUCT:
 "EXTERIOR DOOR PRODUCT"
 8'0" METAL-EDGE STEEL GLAZED
 DOUBLE DOOR UNIT

PART OR ASSEMBLY:
 ANCHORING LOCATIONS
 & DETAILS

REVISIONS	
NO.	DATE
A	12/15/08
	ADDED SPACER
	SWS BY

DATE: 7/25/05
 SCALE: N.T.S.
 DWG. BY: SWS
 CHK. BY:
 DRAWING NO.:
DWG-MA-FL0135-05
 SHEET 3 OF 3