



**HURRICANE BELLEVILLE FIBERGLASS DOOR UNIT  
8'-0" GLAZED DOUBLE DOOR WITH / WITHOUT SIDELITES**

**GENERAL NOTES**

- EVALUATED FOR USE IN LOCATIONS ADHERING TO THE FLORIDA BUILDING CODE AND WHERE PRESSURE REQUIREMENTS AS DETERMINED BY ASCE 7, MINIMUM DESIGN LOADS FOR BUILDINGS AND OTHER STRUCTURES, DOES NOT EXCEED THE DESIGN PRESSURES LISTED.
- WHEN INSTALLED IN THE HIGH VELOCITY HURRICANE ZONE (HVHZ), HURRICANE PROTECTIVE SYSTEM (SHUTTERS) IS REQUIRED.
- POLYURETHANE CORE FLAME SPREAD INDEX OF 50 AND SMOKE DEVELOPED INDEX OF 60 PER ASTM E84.

**4 PLASTICS TESTING OF FIBERGLASS FACING:**

TEST DESCRIPTION	DESIGNATION	RESULT
SELF IGNITION TEMP	ASTM D1929	803 °F > 650 °F
RATE OF BURNING	ASTM D635	0.79 IN/MIN
SMOKE DENSITY	ASTM D2843	48.9%
TENSILE STRENGTH*	ASTM D638	-7.3% DIFF

**5 PLASTICS TESTING OF LITE FRAME MATERIAL:**

TEST DESCRIPTION	DESIGNATION	RESULT
SELF IGNITION TEMP	ASTM D1929	680 °F > 650 °F
RATE OF BURNING	ASTM D635	1.10 IN/MIN
SMOKE DENSITY	ASTM D2843	69.6%
TENSILE STRENGTH*	ASTM D638	-7.48% DIFF

\* COMPARATIVE TENSILE STRENGTH AFTER WEATHERING  
4500 HOURS XENON ARC METHOD 1

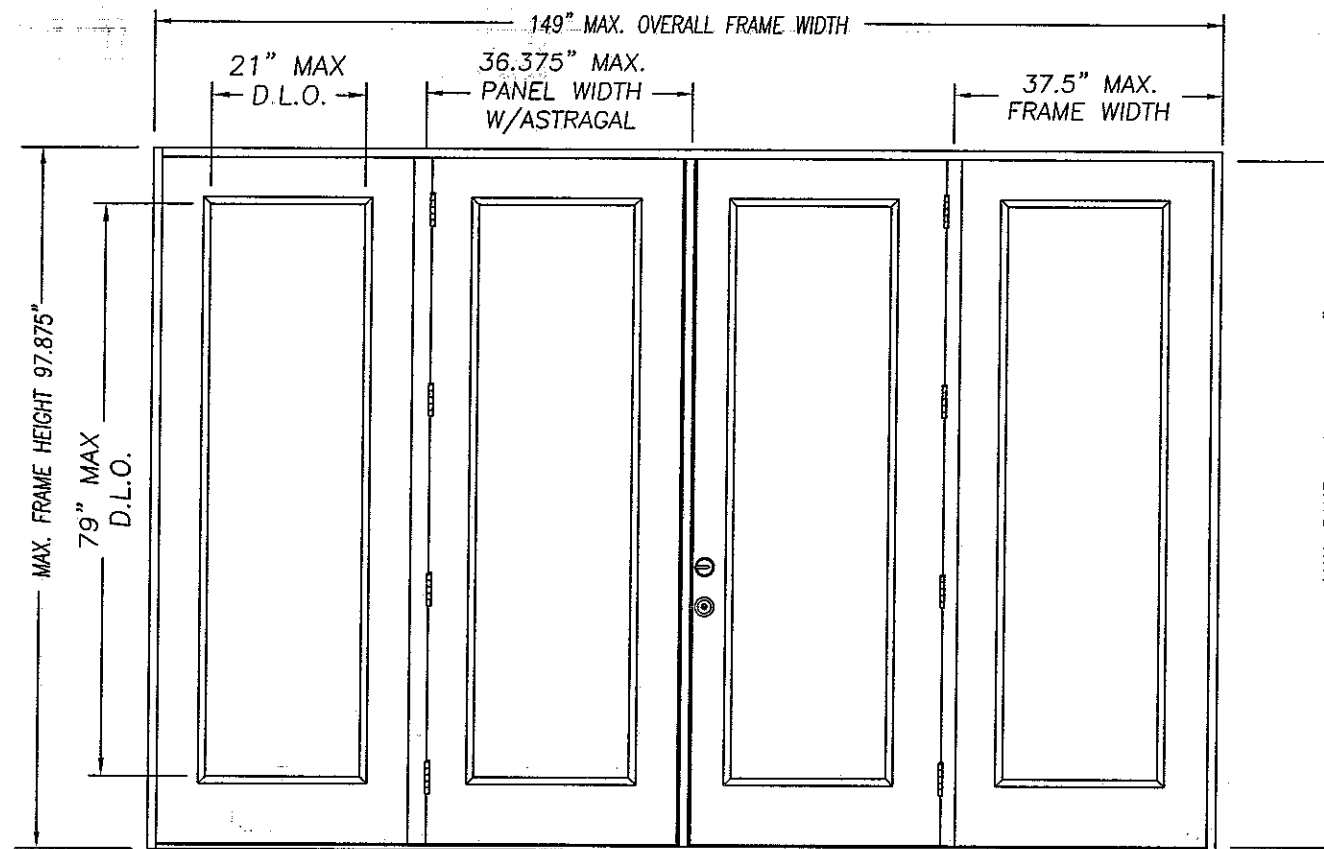

DOUBLE DOOR UNIT W/SIDELITES

Addendum to NAMI

Certification No.: NI007077  
Reviewed By: [Signature]  
Date Reviewed: 4/10/07

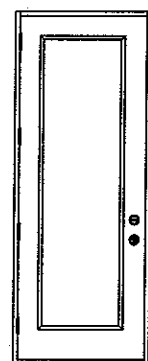

SINGLE DOOR UNIT

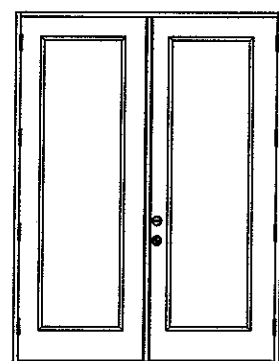

DOUBLE DOOR UNIT

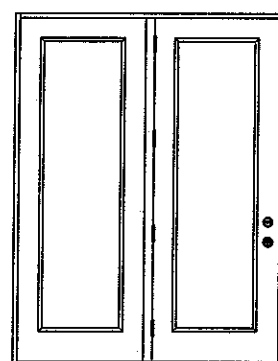

SINGLE DOOR UNIT  
WITH SIDELITE

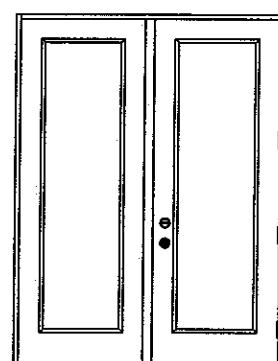

SINGLE DOOR UNIT  
WITH SIDELITE

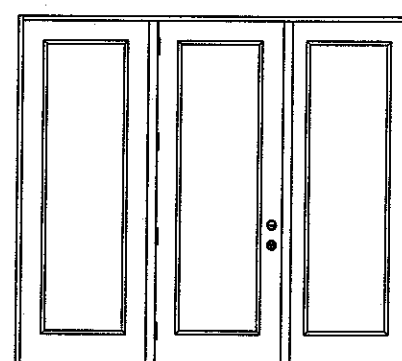

SINGLE DOOR UNIT W/SIDELITES

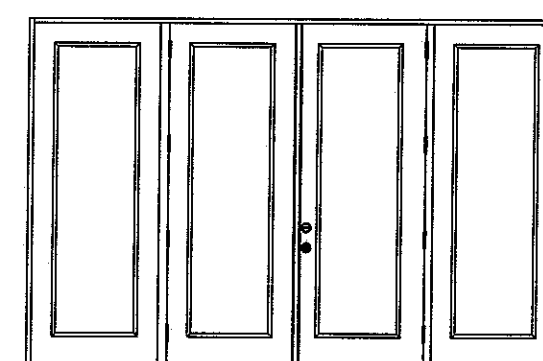

DOUBLE DOOR UNIT W/SIDELITES

CONFIG	MAX WIDTH	DESIGN PRESSURE RATING		WITH SURFACE BOLTS		WHERE WATER INFILTRATION PERFORMANCE IS REQUIRED TO BE 15% OF DESIGN PRESSURE		
		INSWING	OUTSWING	INSWING	OUTSWING	INSWING	OUTSWING	OUTSWING*
X	37.5"	+43.0 / -47.0	+47.0 / -45.0	+55.0 / -55.0	+55.0 / -55.0	+19.0 / -19.0	+40.0 / -40.0	+55.0 / -55.0
XX	74"	+43.0 / -47.0	+47.0 / -45.0	+55.0 / -55.0	+55.0 / -55.0	+19.0 / -19.0	+40.0 / -40.0	+55.0 / -55.0
OX or XO	75"	+43.0 / -47.0	+47.0 / -45.0	+55.0 / -55.0	+55.0 / -55.0	+19.0 / -19.0	+40.0 / -40.0	+55.0 / -55.0
OXO	112.5"	+43.0 / -47.0	+47.0 / -45.0	+55.0 / -55.0	+55.0 / -55.0	+19.0 / -19.0	+40.0 / -40.0	+55.0 / -55.0
OXXO	149"	+43.0 / -47.0	+47.0 / -45.0	+55.0 / -55.0	+55.0 / -55.0	+19.0 / -19.0	+40.0 / -40.0	+55.0 / -55.0

\* High Dam Threshold Design

MASONITE INTERNATIONAL CORP.  
7300 REAMES RD.  
CHARLOTTE, NC 28216

PRODUCT: "EXTERIOR DOOR PRODUCT"  
DOUBLE 8'0" GLAZED  
FIBERGLASS DOOR  
PART OR ASSEMBLY:  
TYPICAL ELEVATIONS  
& GENERAL NOTES

NO.	DATE	REVISIONS	BY

DATE: 4/9/07  
SCALE: N.T.S.  
DWG. BY: SWS  
CHK. BY:  
DRAWING NO.:  
DWG-MA-FL0173-07  
SHEET 1 OF 3



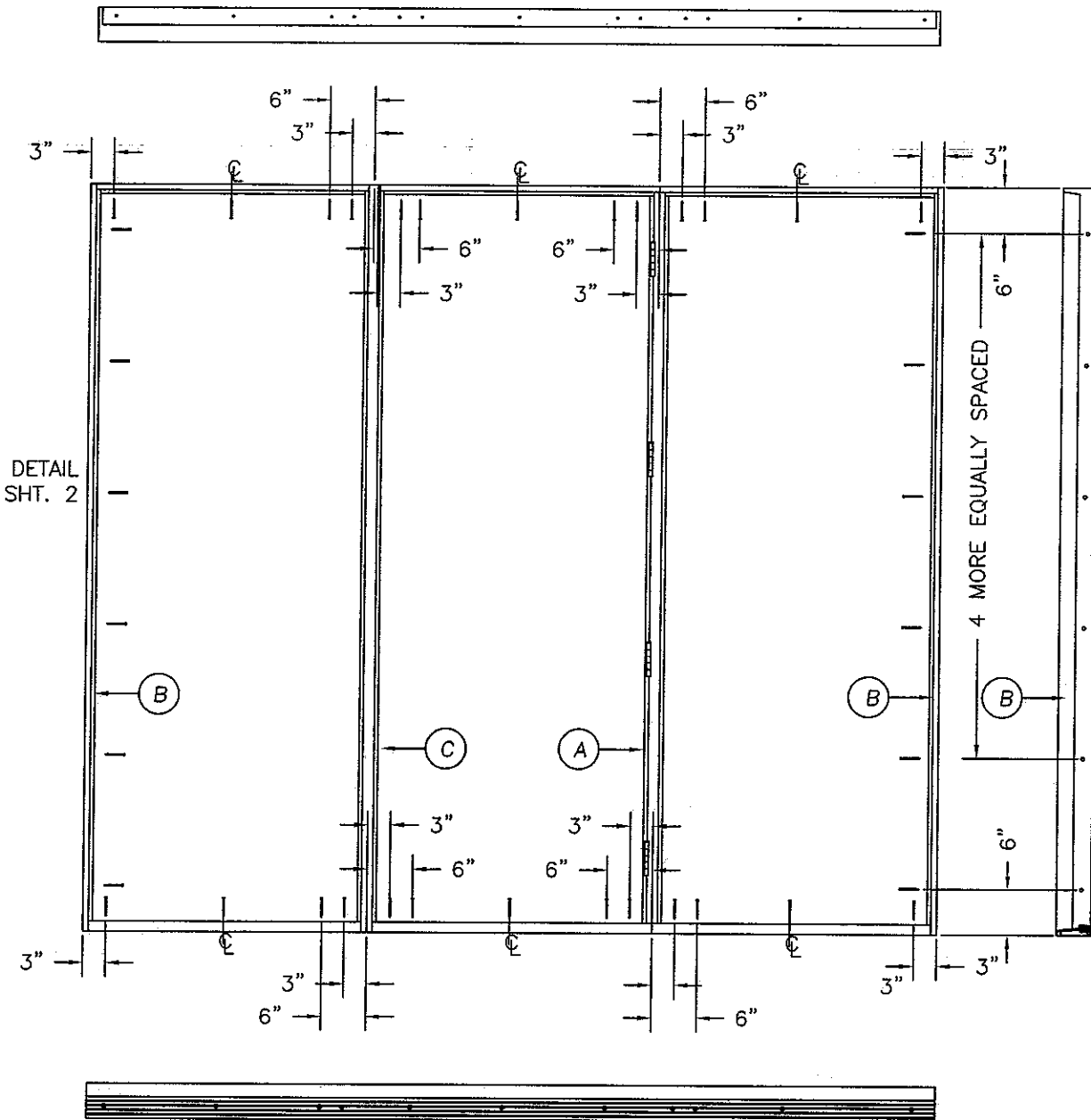
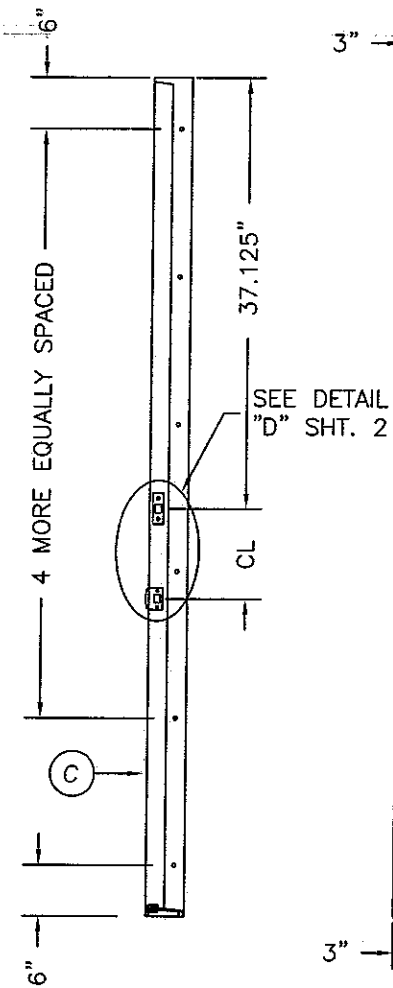
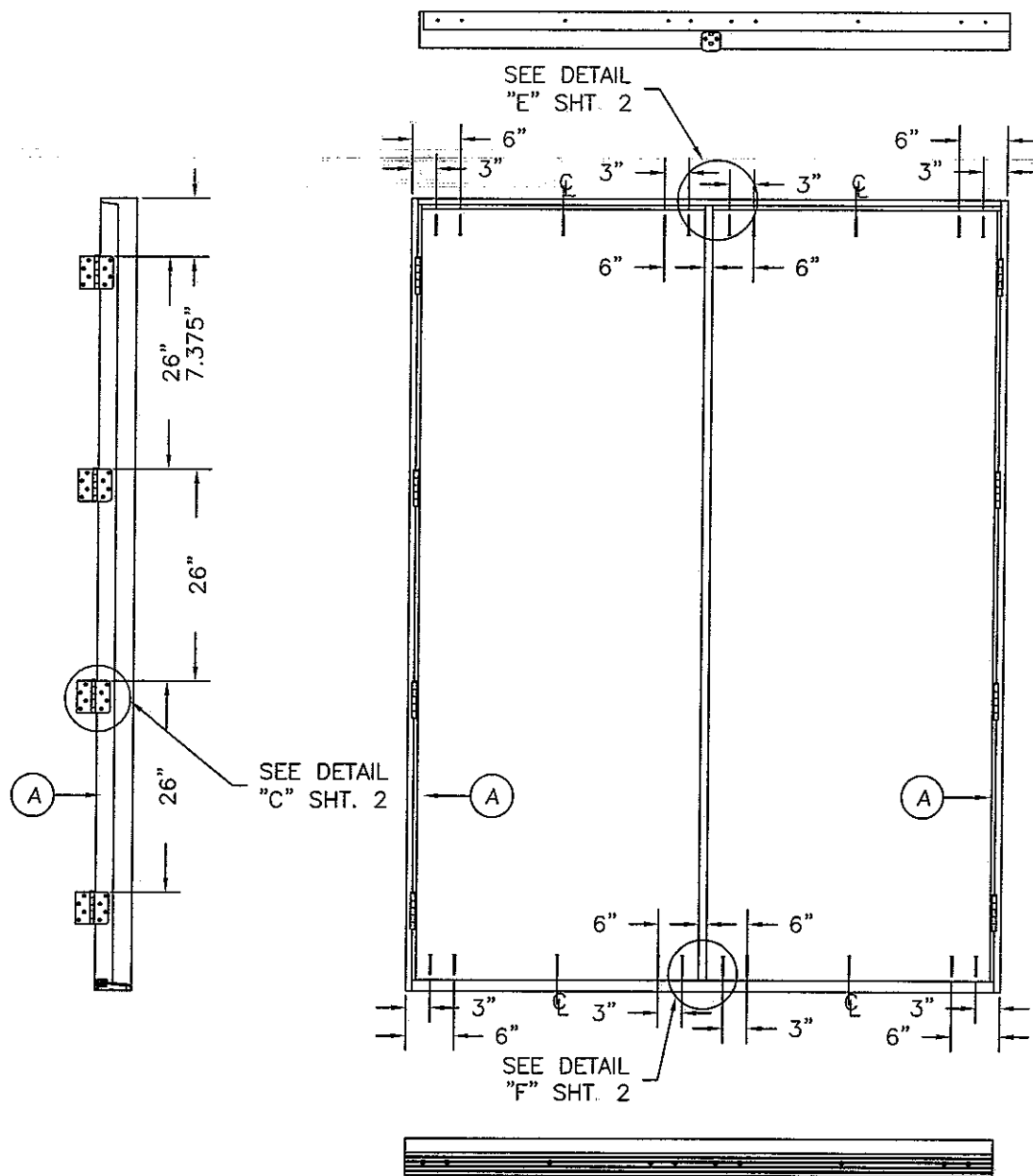

**ATTACHMENT DETAIL**

1. ANCHOR ANALYSIS FOR LOADING CONDITIONS PREPARED, SIGNED AND SEALED BY HAROLD E. RUPP, PE (FLORIDA #15935) WITH THE LOWEST (LEAST) FASTENER RATING FROM THE DIFFERENT FASTENERS BEING CONSIDERED FOR USE. JAMB, HEAD, AND THRESHOLD FASTENERS ANALYZED FOR THIS UNIT INCLUDE #10 WOOD SCREWS OR 3/16" TAPCONS. A PHYSICAL SHIM MUST BE PLACED IN SHIM SPACE AT EACH ANCHOR LOCATION.
2. THE WOOD SCREW SINGLE SHEAR DESIGN VALUES COME FROM ANSI/AF&PA NDA FOR SOUTHERN PINE LUMBER AND ACHIEVEMENT OF 1-1/2" MINIMUM EMBEDMENT. THE TAPCON MUST ACHIEVE MINIMUM EMBEDMENT OF 1-1/4".
3. WOOD BUCKS BY OTHERS MUST BE ANCHORED PROPERLY TO TRANSFER LOADS TO STRUCTURE.
4. MINIMUM DESIGN VALUE STRENGTH OF ANCHORS 171 LBS.

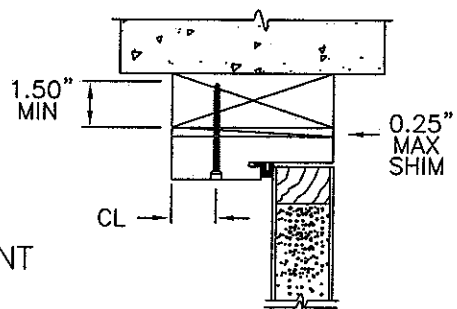

TYPICAL ANCHOR INSTALLATION  
4-9/16" MIN JAMB

**HARDWARE SCHEDULE**

1.	KWIKSET MAXIMUM SECURITY SERIES GRADE 2 CYLINDRICAL AND DEADLOCK HARDWARE TO BE INSTALLED AT 10-1/2" CENTERLINE.
1a.	KWIKSET MAXIMUM SECURITY SERIES GRADE 2 CYLINDRICAL AND DEADLOCK HARDWARE TO BE INSTALLED AT 5-1/2" CENTERLINE MINIMUM WITH 8" GRADE 1 (ANSI/BHMA A156.16) SURFACE BOLTS INSTALLED ON LATCH SIDE OF ACTIVE DOOR PANEL - (1) AT TOP AND (1) AT BOTTOM.
2.	4" X 4" FULL MORTISE BUTT HINGES.

Addendum to NAMI

Certification No.: NI007077  
 Reviewed By: [Signature]  
 Date Reviewed: 4/10/07

MASONITE INTERNATIONAL CORP.  
 7300 REAMES RD.  
 CHARLOTTE, NC 28216

PRODUCT: "EXTERIOR DOOR PRODUCT"  
 8'0" FIBERGLASS GLAZED  
 DOUBLE DOOR UNIT  
 PART OR ASSEMBLY:  
 ANCHORING LOCATIONS  
 & DETAILS

NO.	DATE	BY	REVISIONS

DATE: 4/9/07  
 SCALE: N.T.S.  
 DWG. BY: SWS  
 CHK. BY:  
 DRAWING NO.:  
 DWG-MA-FL0173-07  
 SHEET 3 OF 3